

ME 64

Microphones | Back-Electret Microphone Head Suitable for K6 and K6P Powering Modules

Cat. No. 003282

General Description

The ME 64 is a cardioid microphone head designed for use with the K6 and K6P powering modules. It has a very wide range of applications including reporting, interviews, dubbing, live sound reinforcement and recording applications. Matt black, anodised, scratch-resistant finish.



Pictured with K6 powering module and cable (available separately)

Features

- Cardioid pick-up pattern
- Excellent directivity across whole frequency range
- Very good feedback rejection
- Effective rejection of incidental rear noise
- High speech clarity
- High maximum sound pressure level
- Wide frequency range
- Integrated pop filter
- Delivery includes: ME 64

Recommended Accessories

- MZW 64 foam windshield
- MZW 64 pro foam windshield

Cat. No. 003703

Cat. No. 003711

Technical Data

Pick-up pattern	cardioid
Frequency response	40 – 20,000 Hz ± 2.5 dB
Sensitivity	
(free field, no load) (1 kHz)	31 mV/Pa ± 2.5 dB
Nominal impedance	200 Ω (with K6)
Min. terminating impedance	1 kΩ (with K6)
Equivalent noise level	
A-weighted (DIN IEC 651)	16 dB
CCIR-weighted (CCIR 468-3)	25 dB
Max. SPL (1 kHz)	130 dB (THD = 1 %)
Dimensions	∅ 22.5 x 106 mm
Weight	35 g

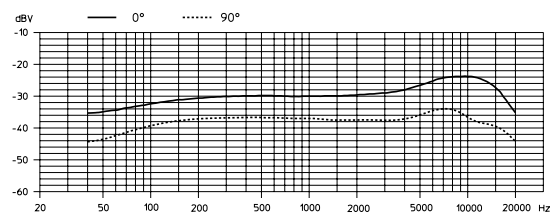
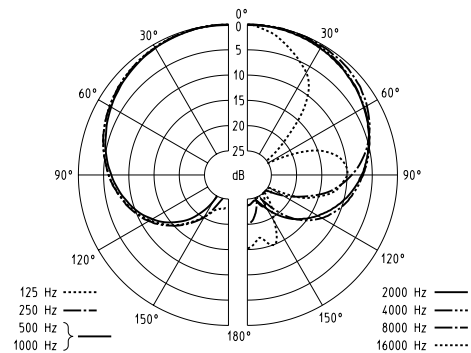

Profile

Cardioid microphone head suitable for K6 and K6P powering modules. Frequency response 40 – 20,000 Hz ± 2.5 dB, sensitivity (free field, no load) 31 mV/Pa ± 2.5 dB at 1 kHz, nominal impedance 200 Ω (with K6), min. terminating impedance 1 kΩ (with K6), equivalent noise level A-weighted 16 dB, CCIR-weighted 25 dB, max. SPL 130 dB at 1 kHz (THD = 1 %), dimensions ∅ 22.5 x 106 mm, weight 35 g.