

SEIT 1928

KONDENSATORMIKROFONE  
FÜR STUDIO - UND MESSTECHNIK

**MICROTECH GEFELL**



## SMS 2000

### Studio Condenser Microphone System in modular design

The miniature condenser microphone system SMS 2000 consists of a microphone preamplifier and exchangeable capsules with the polar patterns cardioid, hypercardioid and omnidirectional. Accordingly, the microphones M 200, M 210 and M 270 are available. This allows universal applications in professional recording and sound reinforcement.

The newly developed, transformerless circuit design substitutes the previous transformer for a symmetrical output stage. The preamplifier is distinguished by its remarkably low intrinsic noise and output capabilities.

The module system adjusted to optimum reproduction properties allows a particularly clean and colourless sound reproduction.

The direction of maximum sensitivity is axial. The studio microphone module system is equipped with a comprehensive range of accessories for widely varying methods of microphone mounting.

It is possible to activate a 10 dB preattenuation for handling very high sound pressure levels. A sensitivity reduction for low frequencies can be utilized to suppress the proximity effect. The two switches are sunk into the middle of the microphone.

The microphones are equipped with a standard 3-pin XLR connector fitting to a microphone cable, e.g. C 70. The operation voltage is provided by 48 V phantom powering according to the international standards DIN 45596 and IEC 268-15. The studio microphone system is available in a satin nickel or a black matt finish.

#### M 20

The microphone capsule M 20 is a pressure gradient transducer with cardioid polar pattern which has well-balanced frequency contours in relation to the sound incidence direction and a desirable smooth presence boost in the upper range.

These properties of the capsule preserve the natural accentuation of soloists and instruments when recording. It is recommended to use a popscreen for close-range applications and to switch the bass roll-off on the preamplifier on.

#### M 21

The pressure gradient transducer M 21 with a hypercardioid polar pattern causes a strong "focussing" of sound in the front half-space and a suppression of crosstalk. The microphone capsule should be used for applications requiring special protection of front-impinging sounds against surrounding noise.

#### M 27

The pressure transducer M 27 with omnidirectional polar pattern is mainly intended for far-field applications. It is insensitive to structure-born noise and wind. The presence boost of 5 dB at 10 kHz is also a warranty for brilliant recordings coming from undefined directions.

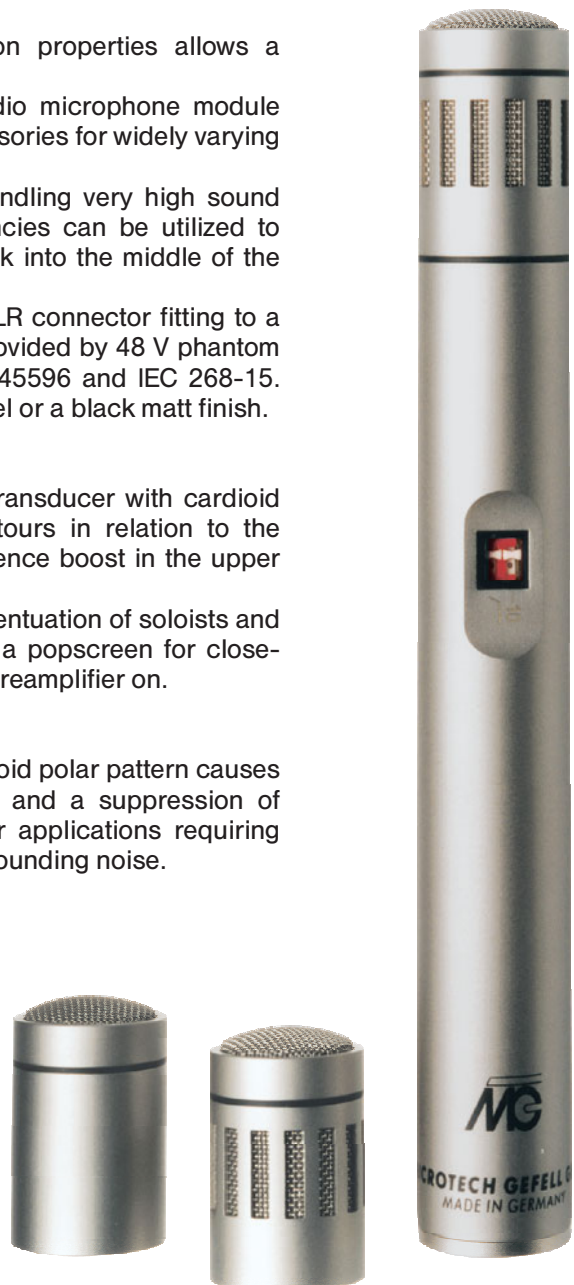

## Delivery

Microphone M 200 in wooden case	L x B x H 210 x 68 x 50 mm	
satin nickel		Order-No. 211116
black matt		Order-No. 211117
Microphone M 210 in wooden case	L x B x H 210 x 68 x 50 mm	
satin nickel		Order-No. 211118
black matt		Order-No. 211119
Microphone M 270 in wooden case	L x B x H 210 x 68 x 50 mm	
satin nickel		Order-No. 211124
black matt		Order-No. 211125

## Accessories, optional

Windscreen, anthracite	W 20	Order-No. 202401
Popscreen, black	PO 70	Order-No. 600018
Microphone holder, Ø 21 mm, satin nickel	MH 64	Order-No. 202302
Microphone holder, Ø 21 mm, black matt	MH 64	Order-No. 202305
Elastic suspension, satin nickel	EA 20	Order-No. 202308
Elastic suspension, black matt	EA 20	Order-No. 202311
Elastic suspension, satin nickel	EH 93	Order-No. 202327
Elastic suspension, dark bronze	EH 93	Order-No. 202328
Table stand, satin nickel	TS 64	Order-No. 212303
Table stand, black matt	TS 64	Order-No. 212308
Double mount, satin nickel	TD 93	Order-No. 202331
Double mount, dark bronze	TD 93	Order-No. 202332
Gooseneck, black	ME 90	Order-No. 202324
Power supply	N 200	Order-No. 202101
Connection cable	C 70	Order-No. 202212

## Specifications SMS 2000

## CE Certificate

Condenser studio microphone system in module construction method

Type		M 200	M 210	M 270
Polar patterns		cardioid	hypercardioid	omni
Frequency range		40 ... 20000 Hz	40 ... 20000 Hz	40 ... 20000 Hz
Sensitivity at 1 kHz		13 mV/Pa	13 mV/Pa	10 mV/Pa
Switch position "reduced bass roll-off" at 60 Hz		-15 dB	-15 dB	-15 dB
Rated impedance		150 Ω	150 Ω	150 Ω
Equivalent loudness level	CCIR 468-4	22 dB	22 dB	26 dB
due to inherent noise	DIN EN 60 651	14 dB - A	14 dB - A	18 dB - A
Signal-to-noise-ratio	CCIR-weighted	72 dB	72 dB	68 dB
(re. 1 Pa at 1 kHz)	A-weighted	80 dB	80 dB	76 dB
Max. SPL for THD ≤ 0,5 %		135 dB	135 dB	138 dB
with 10 dB preattenuation		145 dB	145 dB	148 dB
Total dynamic range of the microphone preamplifier		121 dB	121 dB	120 dB
Current consumption (P 48, DIN 45596, IEC 268-15)		3 mA	3 mA	3 mA
Output connector		3-pin XLR connector goldplated contacts		
Weight		130 g	130 g	130 g
Dimensions (L x Ø)		166 x 21 mm	166 x 21 mm	166 x 21 mm

dB Frequency responses M 200

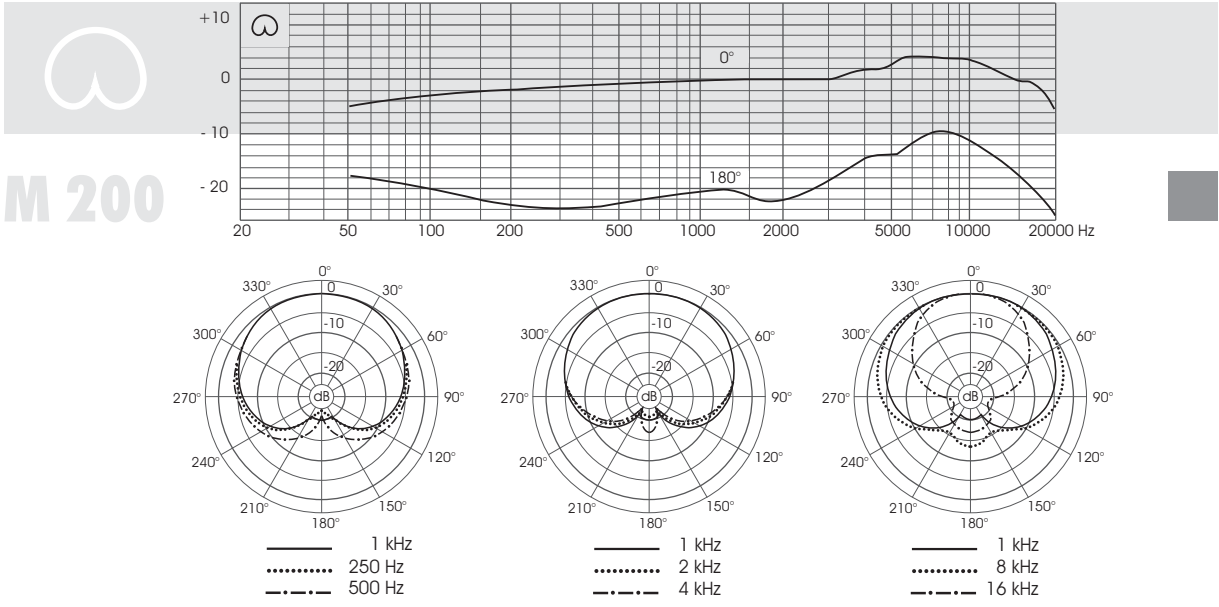

dB Frequency responses M 210

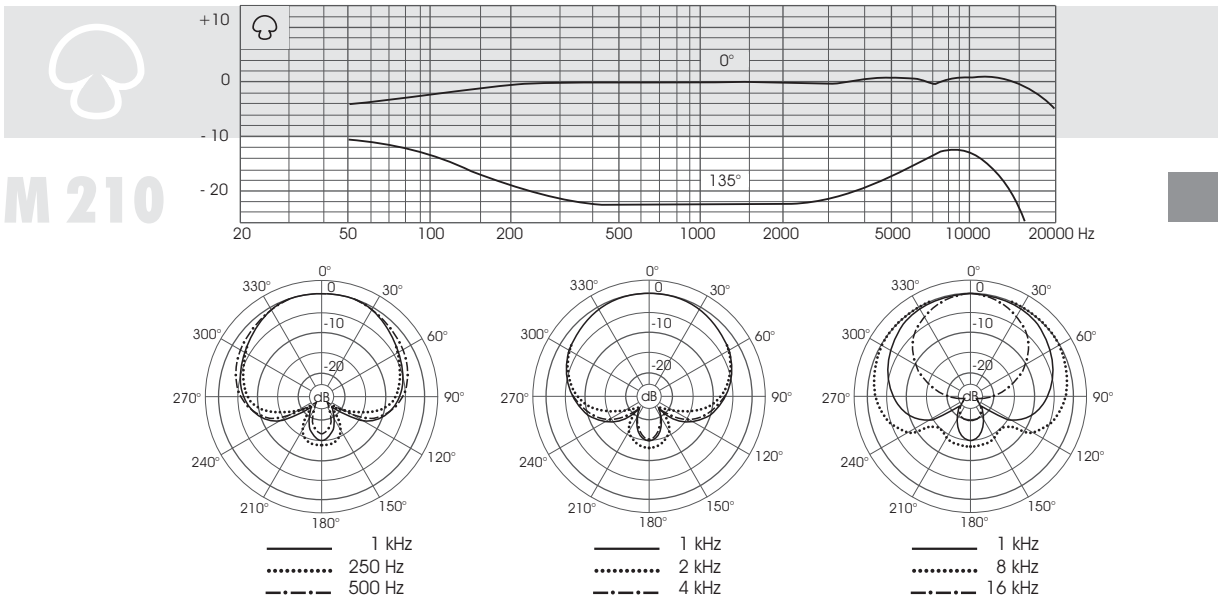

dB Frequency response M 270

