

## e60

The Equitek e60 combines a condenser capsule design with advanced electronics. Typical FET (field effect transistor) condenser microphones use discrete designs. This means they use individual transistors that must be carefully matched for proper characteristics. Even with careful matching, discrete designs are inherently nonlinear. Equitek microphones use a different approach. We do not use any discrete FETs. Instead, we use advanced high speed OpAmps (Operational Amplifiers). These OpAmps are individually laser trimmed for optimum performance and have very high gain. This allows a large amount of negative feedback to be used to significantly reduce any non-linearity. In the past, these OpAmps required more current than typical phantom power supplies can deliver. Some of our equitek series microphones use rechargeable batteries to compensate for this heavy power consumption, but with advances in technologies, and extensive research and development, CAD has eliminated the need for the extra batteries. This allows us to use the same classic Equitek technology in a smaller package. The end result, the e60, a multi purpose, true condenser microphone featuring all the benefits of our earlier equitek microphones yet fitting in the palm of your hand!

## Description

The Equitek e60 from CAD is an externally biased cardioid condenser microphone.

The Equitek e60 incorporates a number of unique features including:

- 16mm, 24k Gold sputtered externally biased condenser capsule.
- 10dB non-capacitive pad
- 4 position hi-pass filter - flat, 40Hz, 85Hz, and 122Hz
- CAD's proprietary discrete linear power supply for efficient low noise and linear power regulation, allows greater dynamic range and lower equivalent self-noise

## Getting Started

The e60 requires 24-48 volt phantom power for proper operation. Before plugging the microphone in, make sure the selected channel is turned off.

**NOTE:** If the microphone is plugged into a hot channel, this will result in a loud "pop" which can possibly damage your audio equipment.

Next, plug the male end of a standard 3 pin mic cable into a mixing console equipped with phantom power, then plug the female end of the cable into the microphone.

Make sure all of the gains are turned down, and the pad switch is in the -10 position.

Finally, turn on the channel which the microphone is plugged into, and turn on phantom power if applicable.

## Caution!

Before using the microphone, the circuit needs to stabilize for a period of 2-3 minutes. Do not switch any of the switches on the back of the e60 until after the initial stabilization time mentioned above. Failure to do so will result in a "pop" similar to plugging the mic into a hot circuit, again this could possibly damage expensive audio gear if done repeatedly.

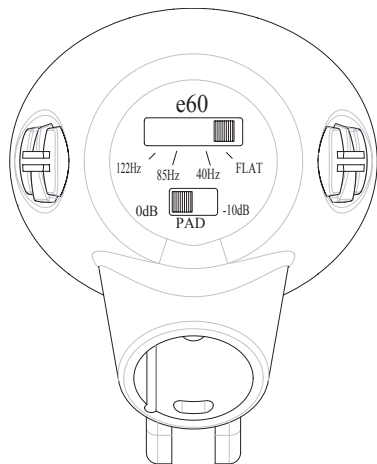

## User Techniques and Applications

The e60 is equipped with a standard 5/8x27 threaded swivel adaptor which fits most microphone stands. Adaptors are widely available in order to make the e60 fit smaller thread mic stands. The e60 is designed specifically for use as an instrument microphone for overheads, hi-hats and pianos. The e60 is great for virtually all acoustic, wind, and amplified instruments. One of the most popular uses for the e60 is in miking drum sets, ideally in an overhead type configuration. The e60 also excels at miking stringed instruments such as acoustic guitars. The e60 has a four position roll-off which allows for extended "tuning" of the frequency response at the microphone for your particular application. (See the frequency response chart for more details). The e60 is also equipped with a -10dB pad switch to reduce the output level of the microphone by 10dB accordingly. If your board is "clipping" or distorting when using the e60, try switching the pad switch to the -10dB position. Alternatively, if your are not getting enough signal from the microphone, switch the pad switch to the 0dB position.

The e60 microphone uses a true condenser microphone element. As with any studio condenser microphone, special care should be taken to keep the microphone clean and dry. It is highly recommended the e60 be stored in its included vinyl pouch in a cool, dry environment to ensure long life of the capsule when not in use. If the e60 is used in a vocal application, it is very important to use a fabric "pop" filter such as a CAD EPF-15A positioned between the user and the microphone. Pop filters do not adversely effect the performance of the microphone in any way.

## Frequency Response

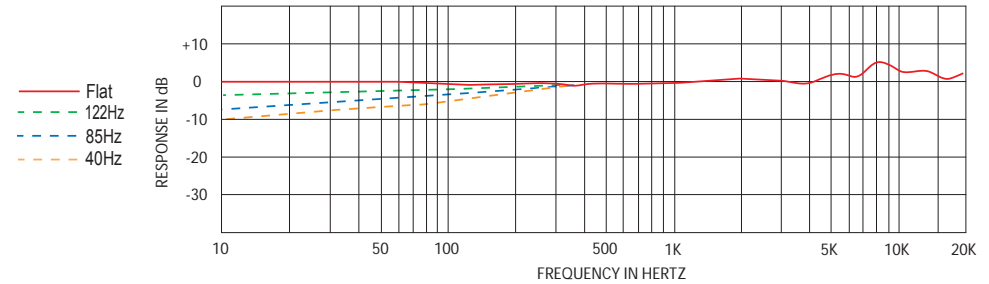

## Polar Pattern

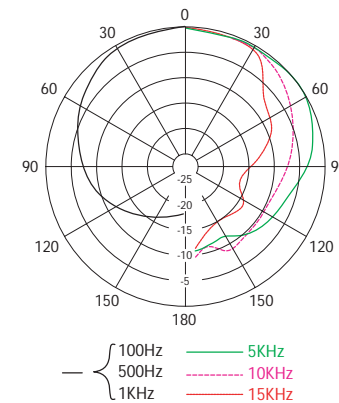

## Optional Accessories:

- EPF-15A ... P-pop filter mounted on 15" gooseneck with standard bracket
- 40-350 ..... 50 ft. broadcast quality extension cable terminated with professional 3 pin male/female connectors.
- 40-351 ..... 100 ft. broadcast quality extension cable.
- 40-352 ..... 25 ft. broadcast quality extension cable.

## Specifications

**Type:**

Front Address, Externally Biased Condenser.

**Frequency Response:**

30-20 kHz

**Polar Pattern:**

Cardioid

**Impedance:**

300 ohms

**Sensitivity:**

-41 dBV (8.9mV) @ 1Pa

**Equivalent Noise Level:**

22 dB Equivalent SPL, A weighted.

**Maximum SPL:**

140 dB SPL (with pad on), 1% THD, 1KHz

**Powering:**

P24, P48, 6mA

**Connector:**

Three pin male XLR type.

**Finish:**

Durable black "leather feel" urethane.

**Net Weight:**

11.5oz. (326 grams).

\*In our constant efforts to maintain excellence, CAD Professional Microphones reserves the right to change these specifications at any time and without prior notice.

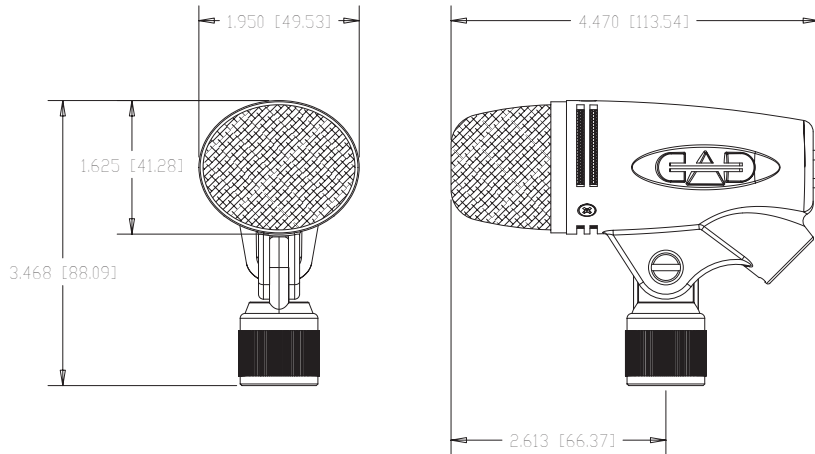

**Professional Microphones**

A Division of Omnitronics LLC

341 Harbor St., Conneaut Ohio, 44030 USA

Sales: 800-762-9266 • Fax 440-354-8481 • Customer Service: 440-593-1111 x 212

[www.cadmics.com](http://www.cadmics.com)

p/n 46873-30-00, rev2, 7/17/2006, S.L.W.



e60  
Externally Biased  
Cardioid Condenser Microphone



User Manual / Specification Sheet